



CABINET HARDWARE SYSTEMS

BUILDERS' HARDWARE

#BLD

Australia

1800 008 591 ■ www.artia.com.au

VICTORIA:

235 Settlement Road,
Thomastown VIC 3074

NEW SOUTH WALES:

Unit 1/429 Victoria Street,
Wetherill Park NSW 2164

QUEENSLAND:

Building 2/660 MacArthur
Avenue, Pinkenba QLD 4008

SOUTH AUSTRALIA:

13 Rosberg Road,
Wingfield SA 5013

WESTERN AUSTRALIA:

Unit 1B/15 Hector Street,
Osborne Park WA 6017

New Zealand

0800 267 625 ■ www.artia.co.nz

AUCKLAND:

11 Bruce Roderick Drive,
East Tamaki, Auckland 2013

CHRISTCHURCH:

117 Wrights Road,
Addington, Christchurch 8024

BUILDERS' HARDWARE

CONTENTS

WARDROBE FITTINGS

03

▪ Hang Rails – Oval.....	03
▪ Supports – Oval.....	03
▪ Hang Rails – Round.....	04
▪ Supports – Round.....	05
▪ Storage.....	06
▪ General Hardware.....	07

GENERAL HARDWARE

07

▪ Toilet Partition Hardware.....	07
▪ Wardrobe Hooks.....	11
▪ Door Stops.....	12
▪ Cabinet Catches.....	12
▪ Locks Accessories.....	13
▪ Recreational Locks.....	14
▪ Cabinet Hinges.....	15
▪ Shelf Supports.....	16
▪ Shelf Brackets.....	17
▪ Glass And Mirror Clips.....	18
▪ Levellers.....	18
▪ Protectors.....	18
▪ Cash Management.....	19
▪ Tube Closures.....	21
▪ Sockets For Stem Castors & Glides.....	27
▪ Threaded Adaptors.....	27
▪ Tube Connectors.....	28
▪ Tube Glides.....	28
▪ Reducing Bushes.....	28
▪ Handwheels.....	28
▪ Handwheels.....	29
▪ Spacers.....	30
▪ Stem Bumpers.....	30
▪ Nylon Bushes.....	30

OFFICE FURNITURE EQUIPMENT

31

▪ Cable Outlets.....	31
▪ Divider.....	31

INDEX

32

BUILDERS' HARDWARE

WARDROBE FITTINGS

HANG RAILS – OVAL

▶ Hang Rail – Oval – Aluminium

- Plain design
- 30mm x 15mm tube x 1.2mm wall
- 4 metre length
- Carton packaging

Code	Finish	Pack Size
640130	chrome	5



▶ Hang Rail – Oval – Aluminium

- Ribbed design
- 30mm x 15mm tube x 1.2mm wall
- 4 metre length
- Carton packaging

Code	Finish	Pack Size
640135	chrome	5



▶ Hang Rail – Oval – Steel

- 30mm x 15mm tube x .7mm wall
- 3 metre length
- Carton packaging

Code	Finish	Pack Size
291.30153.340	chrome	10



SUPPORTS – OVAL

▶ End Pillar Supports – Oval Tube – Zinc

Code	A	B	Finish	Pack Size
630131	30	15	chrome	20



▶ Centre Pillar Supports – Oval Tube – Zinc

Code	A	B	Finish	Pack Size
630132	30	15	chrome	20

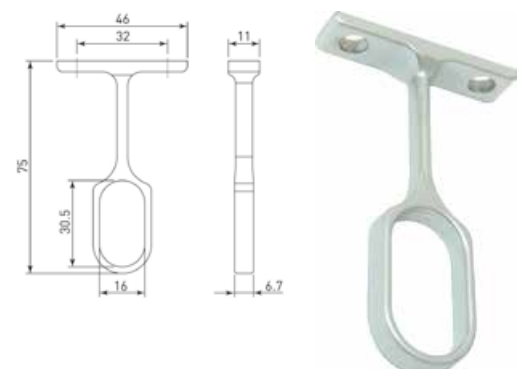

BUILDERS' HARDWARE

SUPPORTS – OVAL

► Flange Supports – Oval Tube – Zinc

- Screw fix
- 32mm c/c
- Hole for securing tube

Code	A	B	Finish	Pack Size
630130	30	15	chrome	20

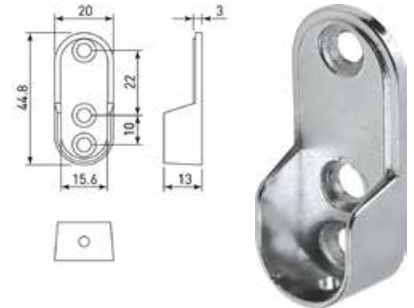

► Flange Supports – Oval Tube – With Pins – Zinc

- Quick fixing oval end flange
- 2 pins, 5mm
- 32mm c/c
- Hole for securing tube

Code	A	B	Finish	Pack Size
630129	30	15	chrome	20

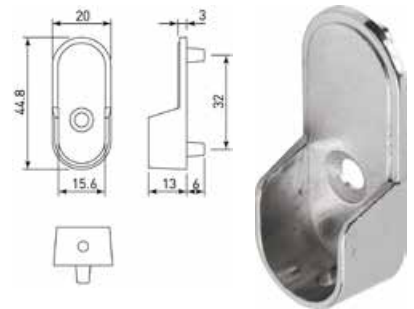

HANG RAILS – ROUND

► Hang Rail – Round – Aluminium

- 25mm diameter tube x 1.2mm wall
- 4 metre length
- Carton packaging

Code	Ø	Finish	Pack Size
640125	25	chrome	10



► Hang Rail – Round – Aluminium

- 19mm diameter tube x .9mm wall
- 25mm diameter tube x 1.2mm wall
- 3 metre length
- Carton packaging

Code	Ø	Finish	Pack Size
290.91930.340	19	chrome	10
290.92530.340	25	chrome	10



BUILDERS' HARDWARE

SUPPORTS – ROUND

► Flange Supports – Round Tube – Zinc

Code	Ø	Finish	Pack Size
630119	19	chrome	100
630125	25	chrome	50



► End Pillar Supports - Round Tube - Zinc

Code	Ø	Finish	Pack Size
630120-1	19	chrome	20
630126-1	25	chrome	20

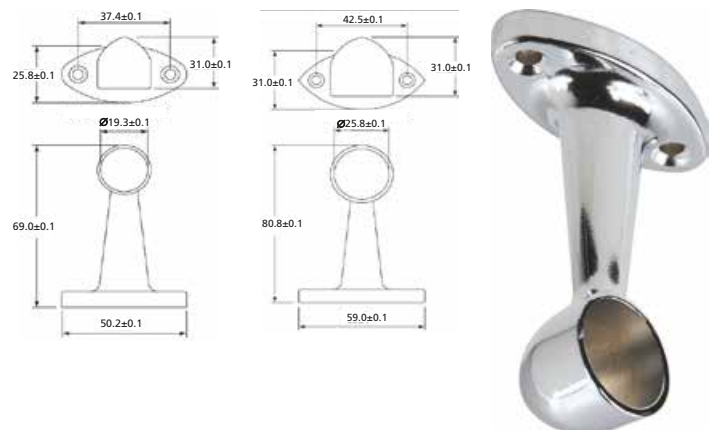

► Centre Pillar Supports - Round Tube - Zinc

Code	Ø	Finish	Pack Size
630121-1	19	chrome	20
630127	25	chrome	20

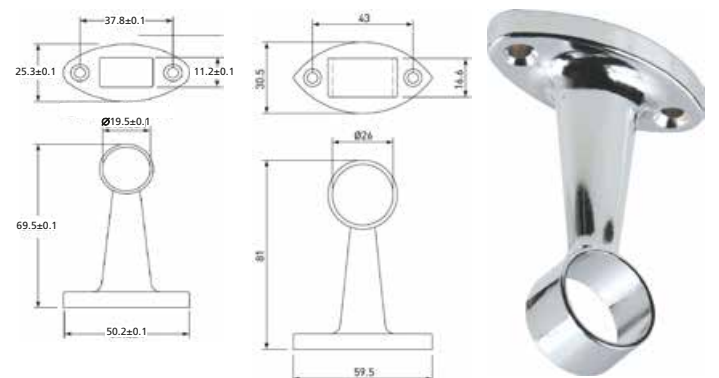

BUILDERS' HARDWARE

STORAGE

▶ Trouser Practic

- Keep clothes neat, tidy and uncrushed
- Patented system pulls out and fans easily to select or replace garments
- Tiny nodules on the top of the arm prevent trousers from slipping
- Dresses can be hooked onto the support underneath each arm
- Strong and durable thermoset moulded hanging arm
- Available in two sizes; 14 or 18 arms
- Repon ball-bearing slides with 30kg load capacity

Code	Width	Depth	Bars
503018	450	450	14
503020	600	450	18

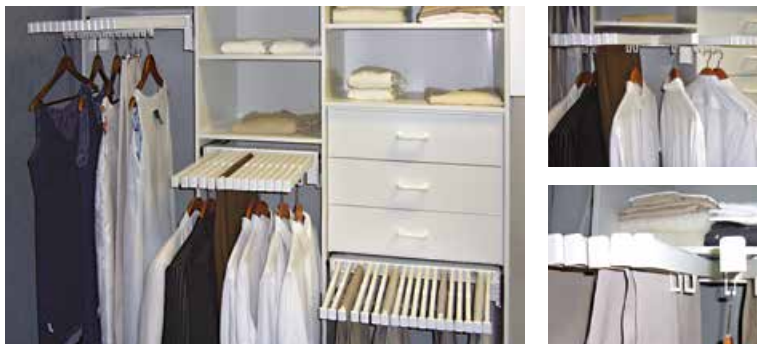

▶ Sugatune Tallman – Dual Mount

- Dual pull down mechanism mounted between carcase walls
- Grey enamelled steel arm with grey plastic body
- Cantilever hanging tube (laquered steel) is suitable for loads up to 20kg
- Pendant handle of grey enamel steel and grey hand grip
- Dual mounting to suit 800 – 1180mm wide unit (adjustable)

Code	Width	Type
185012	1180	Dual

SUGATSUNE

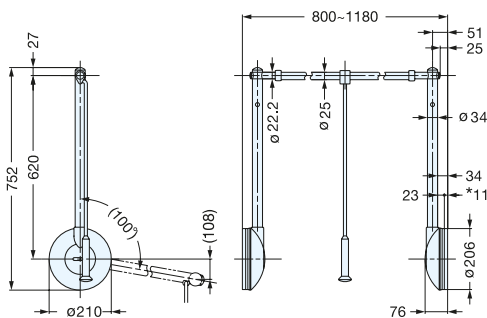

*Thickness of Distance Plate

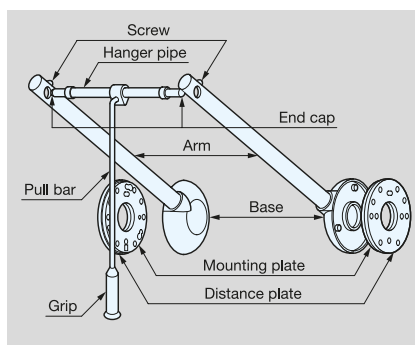

BUILDERS' HARDWARE

GENERAL HARDWARE

TOILET PARTITION HARDWARE

► Gravity Hinge Set

- Sets supplied with screw fixed fittings allowing usage on different material thicknesses. 18mm is suggested size
- Hinges are handed, a left-hand set (as viewed from the outside) comes with a right-hand hinge (as viewed from the inside)
- Hold open only
- Set includes:
 - 1 x pair gravity hinges
 - 1 x door bumper
 - 1 x door turnbolt
 - 1 x turnbolt Z staple
 - 1 x turnbolt indicator
 - 1 x coat hook
- Includes screws
- Satin chrome finish

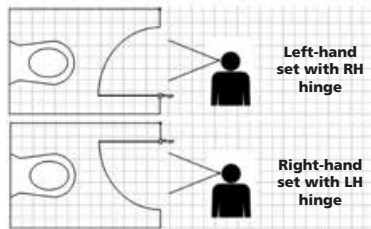

Code	Set (as viewed from outside)	Depth	Bars
776245	left hand	open	1 set
776250	right hand	open	1 set

bolt through, hold close, concealed fix options available as buy in only

► Stainless Steel Spring Hinge Set

- Suited to 18mm thick material
- Thicker material can be accommodated by requesting longer fixing threads
- Hinges are non-handed
- Hold open or hold closed
- Set includes:
 - 1 x pair stainless steel spring hinges with dress plates
 - 1 x door bumper
 - 1 x door turnbolt
 - 1 x turnbolt staple
 - 1 x turnbolt indicator
 - 1 x coat hook
 - 10 x 35mm all threads
 - 20 x nickel finish acorn nuts
- Satin chrome finish

Code	Hold	Pack Size
776320	open	1 set
776321	closed	1 set



BUILDERS' HARDWARE

TOILET PATITION HARDWARE

► Brass Spring Hinge Set

- Suited to 18mm thick material
- Thicker material can be accommodated by requesting longer fixing threads
- Hinges are non-handed
- Set includes:
 - 1 x pair spring hinges with dress plates
 - 1 x door bumper
 - 1 x door turnbolt
 - 1 x turnbolt staple
 - 1 x turnbolt indicator
 - 1 x coat hook
 - 10 x 35mm all threads
 - 20 x nickel finish acorn nuts
- Satin chrome finish



Code	Hold	Pack Size
776165	closed	1 set

► Gravity Hinges

- Gravity hinges automatically move to hold open position when door is not locked (hold closed available as buy in only)
- Hinges lift off for safety
- Available in left or right handed, doors are handed from outside
- Includes screws
- Can be used as bolt through, for 18mm use with 38mm all-threads and acorn nuts
- Sold as pairs
- Satin chrome finish

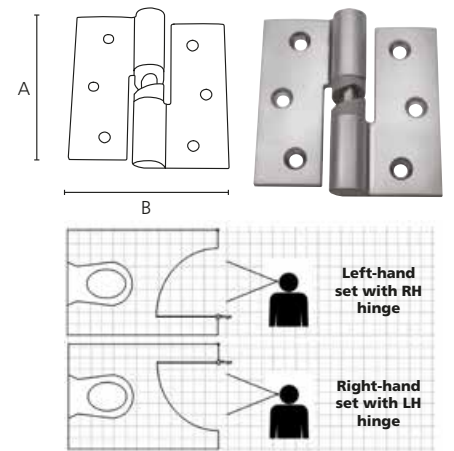

Code	Set (as viewed from outside)	A	B	Pack Size
776037	right hand	80	85	1 pair
776038	left hand	80	85	1 pair

► Spring Hinges – Stainless Steel

- Spring hinges return to open or closed position when not locked
- 304 Grade stainless steel
- Available in hold open or hold closed
- Includes 8 x 35mm all-threads to suit 18mm material
- 16 x nickel finish acorn nuts
- 4 x face plates
- 47mm C/C
- Sold as pairs
- Brushed stainless finish

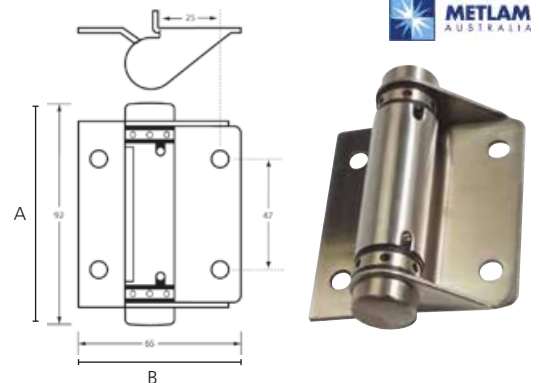

Code	Hinge Type	A	B	Pack Size
776305	open	92	80	1 pair
776310	closed	92	80	1 pair

BUILDERS' HARDWARE

TOILET PARTITION HARDWARE

► Spring Hinges – Brass

- Spring hinges return to open or closed position when not locked
- Brass hinge
- Non handed
- Available in hold open or hold closed
- Includes 8 x 35mm all-threads
- 16 x nickel finish acorn nuts
- 4 x face plates
- 47mm C/C
- Sold as pairs
- Satin chrome finish

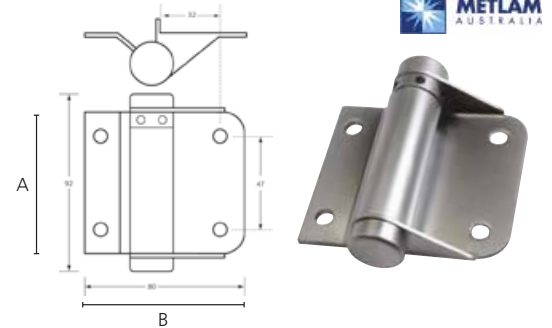

Code	Hinge Type	A	B	Pack Size
776002	open	92	80	1 pair
776005	closed	92	80	1 set

► Turnbolt and Indicator Sets

- Includes staples and plates
- Available in rectangular, rectangular safety or round
- Includes screws
- Satin chrome finish

Code	A	B	Pack Size
776055	60	45	1 set
776052	60	45	1 set
776053	50	n/a	1 set

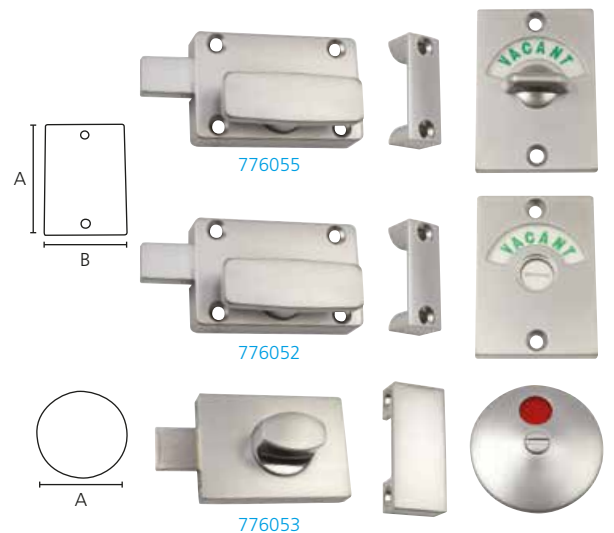

► Bumpers

- Door bumpers provide cushioned stop for doors
- Face mount
- Satin chrome finish

Code	A	B	C	Pack Size
776059	48	54	18	1
776061	50	62	13	1
776064	50	33	15	1

Includes bolts and nuts

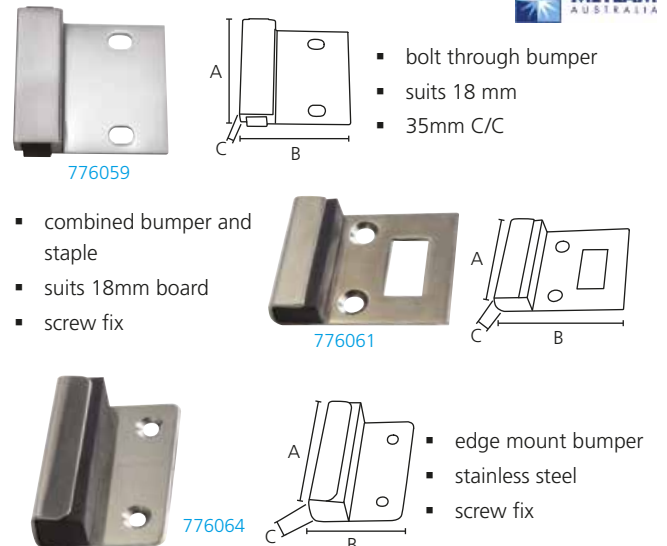

BUILDERS' HARDWARE

TOILET PATITION HARDWARE

► Toilet Roll Holder

- 304 Grade stainless steel
- Economical, simple design
- Brushed stainless steel finish
- Other styles available on request
- Screws included

Code	A	B	C	Pack Size
776069	25	135	70	1

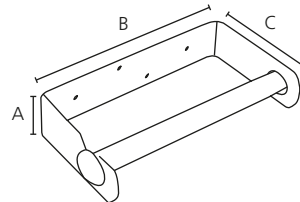

► Assembly Fittings

- Acorn nuts – 1/4" thread
- To suit bolt through applications
- Use with all threads and dress plates
- Satin chrome finish

Code	Pack Size
776108	20

- All threads – 1/4" thread
- To suit bolt through applications
- Use with acorn nuts and dress plates
- Available in 3 sizes to suit different applications
- 35mm suits 18mm
- 38mm suits 18mm with gravity hinges
- 50mm suits 33mm

Code	A	B	Pack Size
776110	1/4"	35	10
776111	1/4"	38	10
776113	1/4"	50	10

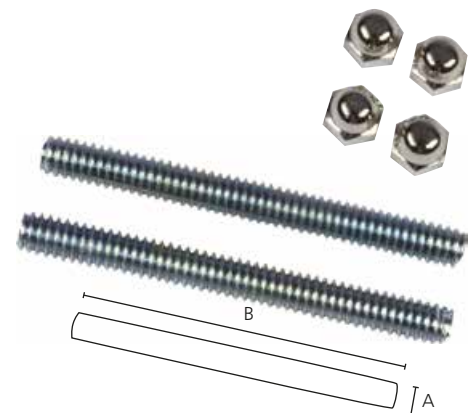

► Channel

- Anodised aluminium sections for panel ends
- Suits 18mm board
- Available in twp lengths, 1800mm and 2100mm
- Satin aluminium finish

Code	A	Pack Size
WACH_18_18	1800	20
WACH_18_36	2100	20

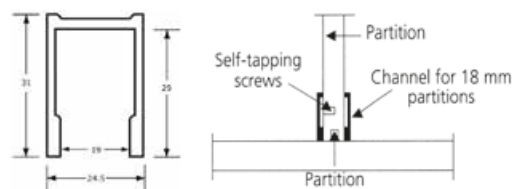

► Insert

- Insert for aluminium channel
- Available in 2700mm length
- Satin aluminium finish
- Suits channel above

Code	A	Pack Size
WAINS_18	2700	20

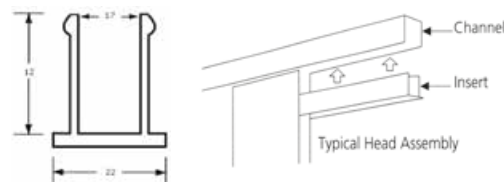

► Leg

- Stainless steel adjustable leg 200mm
- Adjustable from 175mm - 225mm
- Suits centre of panel
- Brushed stainless steel finish
- Other sizes available, buy in only

Code	A	Pack Size
776138	200	1

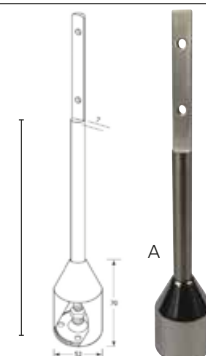

BUILDERS' HARDWARE

TOILET PARTITION HARDWARE

▶ Leg

- Stainless steel adjustable leg 200mm
- Adjustable from 175mm - 225mm
- For angle fixing
- Brushed stainless steel finish
- Other sizes available, buy in only

Code	A	Pack Size
776136	200	1



▶ Leg Bracket

- Stainless steel 2 way leg bracket
- For joining centre partition
- Use with 776136 leg, (change head section)
- Brushed stainless steel finish
- 95mm wide x 40mm x 60mm depth with 20mm channel

Code	A	Pack Size
776103	200	1

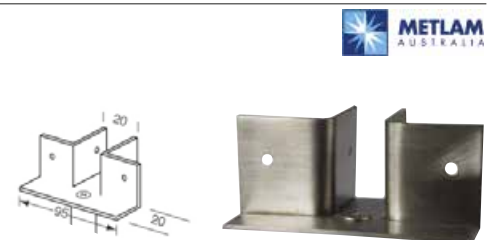

▶ Hat & Coat Hook

- Zinc diecast
- Double hook
- Includes screws
- Satin chrome finish
- C = projection

Code	A	B	C	Pack Size
776043	64	18	93	1

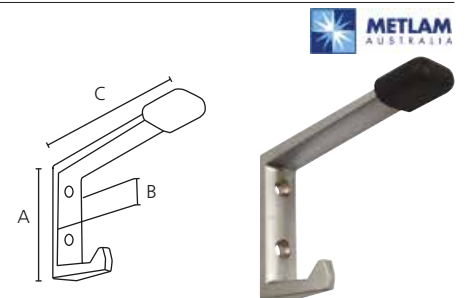

WARDROBE HOOKS

▶ Wardrobe Hook

- Zinc diecast
- Double hook
- Strong square mounting plate
- Includes screws
- Satin chrome finish
- C = projection

Code	A	B	C	Pack Size
582021	72	34	80	20

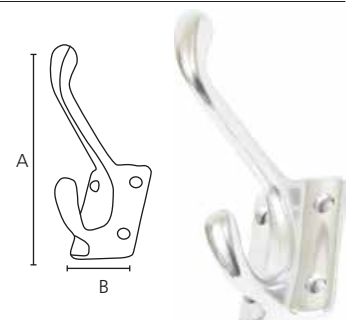

▶ Wardrobe Hook

- Zinc diecast
- Single hook
- Includes screws
- Chrome finish
- C = projection

Code	A	B	C	Pack Size
274.03102.387	45	18	37	50

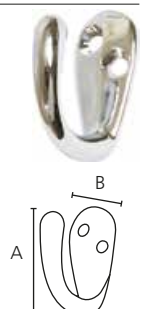

BUILDERS' HARDWARE

DOOR STOPS

▶ Heavy Duty

- Heavy duty magnetic catch
- Holds up to 20kg
- Available in floor mount only
- Grey finish



Code	D
015037#	floor

▶ Econo Catch

- Economical plastic door stop and catch
- Holds door open
- Screw fix
- White finish

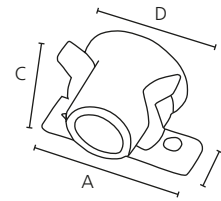

Code	A	B	C	D	Pack Size
787015	42	12	25	27 dia.	5

CABINET CATCHES

▶ Double Roller Catch

- Body zinc plated steel
- Strike zinc plated steel
- Fixing screws included
- Zinc plate finish



Code	Pack Size
215.01100.352	100

▶ Nylon Gripper Catch

- Nylon gripper with strike pin
- Fixing screws included
- White finish



Code	Pack Size
215.42100.352	250

▶ Double Ball Catch

- 38mm, 43mm, 49mm and 60mm
- Solid brass body with adjustable tension on ball bearings
- Solid brass strike
- Brass finish

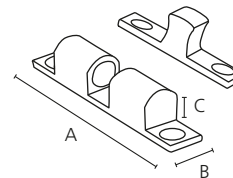

Code	A	B	C	Pack Size
215.71338.420	38	8	9	50
215.71343.420	43	8.5	9.5	40
215.71349.420	49	9	10	40
215.71360.420	60	10.5	11.5	20

▶ Bi Fold Corner Protector – Side Mounting

- Suits 2 door corner unit.
- Prevents dropping of bi fold door and accidental damage
- Positively locates and holds door closed
- White finish

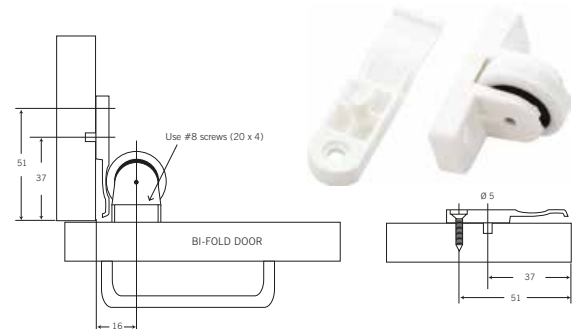

Code	Pack Size
215.11139.001	25

BUILDERS' HARDWARE

CABINET CATCHES

► Bi Fold Corner Protector Top Mounting

- Suits 3 door extended corner unit
- Prevents dropping of bi fold door and accidental damage
- Positively locates and holds door closed
- White finish

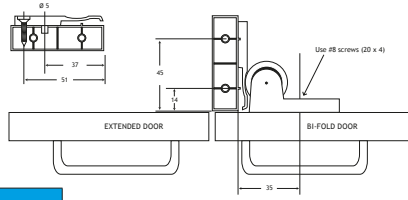

Code	Pack Size
215.11140.001	15

► Mini Latch

- Push door to open / push door to close
- Suitable for flush, inset or rebated doors with non self closing hinges
- Fixing screws included
- Nickel plate / white
- Nickel plate / brown

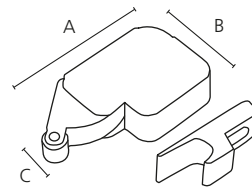

Code	A	B	C	Finish	Pack Size
054535	37	28	12	NP / white	50

► Magnetic Catch – 6kg

- Semi floating magnet ensures full contact with strike plate
- Elongated fixing holes for adjustment
- 6kg holding capacity
- Brown and white finish

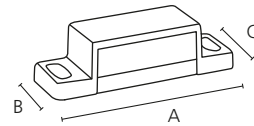

Code	A	B	C	Finish	Pack Size
054210	45	14	12	brown	100
054212	45	14	12	white	100

► All Metal Magnetic Catch

- High quality diecast body
- Elongated fixing holes for adjustment
- Self aligning contact plate
- Electroplated brass finish

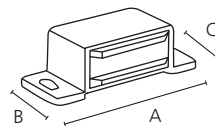

Code	A	B	C	Pack Size
426330	46	13	14	10
426332	46	18	14	10
426334	46	23	15	10
426336	46	33	15	10

► Strike Plate

- For use on timber doors with magnetic touch catches
- One piece with single central fixing hole
- Zinc plate finish

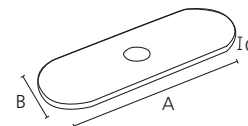

Code	A	B	C	Pack Size
270208	35	12	1.5	500

LOCKS ACCESSORIES

► Striker Plates

- Metal lock strikers door use with drawer – door and cam locks
- 426276 Multi-drawer strike plate
- Nickel plated finish

Code	A	B	C	Pack Size
426270	20	13	8	nickle plated
426272	37	13.5	8	nickle plated
426276	45	10	24	nickle plated

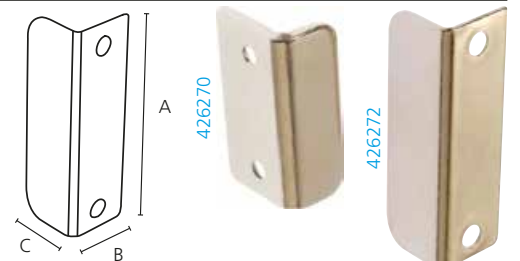

BUILDERS' HARDWARE

RECREATIONAL LOCKS

► Tener

- Recessed push button latch and knob fitting
- Lock body mounts on inside face of door
- Boring through door required for knob and rosette
- 25mm diameter knob, suits 20mm door thickness
- Brown plastic with brass plated knob / rosette, or matt nickel finish

	Code	Finish	Pack Size
A	270376	matt nickel	100
B	270379	matt nickel	100
C	270378	matt nickel	100

FINISHED PRODUCT
(A, B, C)



A. Component



B. Component



C. Component



► Tiera

- Mini version of Tener
- 20mm diameter knob, suits 16mm door thickness
- Brown plastic or matt nickel finish

	Code	Finish	Pack Size
A	270383	brown	100
A	270388	matt nickel	100
B	270387	matt nickel	100
C	270386	matt nickel	100

FINISHED PRODUCT
(A, B, C)



A. Component



B. Component



C. Component



BUILDERS' HARDWARE

CABINET HINGES

▶ Piano Hinge

- Supplied in 2m lengths or 25m coils
- Pin diameter 1.75mm
- Material thickness 22g or 0.07mm
- Stainless steel = us304b/403 where nominated

Code	A	Pack Size
075346	2m	Stainless steel
075350	2m	Polished brass
075360	25m	Electro brass plated steel
075362	25m	Florentine bronze plated steel
075364	25m	Nickel plated steel
075366	25m	Stainless steel

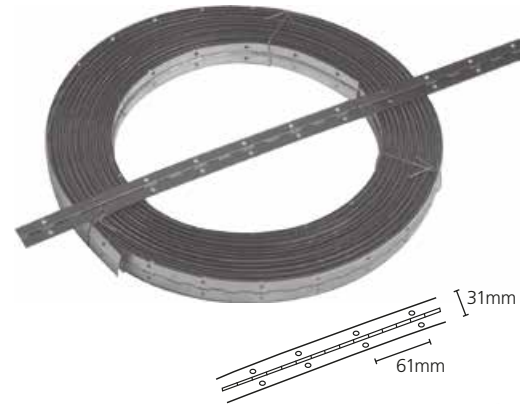

▶ Decorative Butterfly Hinge

- Light duty
- Decorative design
- Includes screws
- Electroplated brass finish

Code	A	B	Pack Size
221.35025.344#	25	9.5	1000

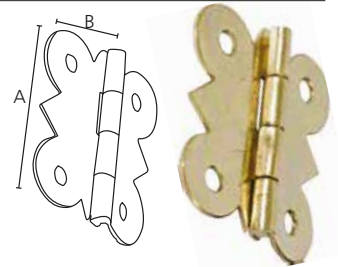

▶ Decorative Butterfly Hinge

- Decorative design
- Florentine bronze finish

Code	A	B	Pack Size
221.12036.337	36	25	100

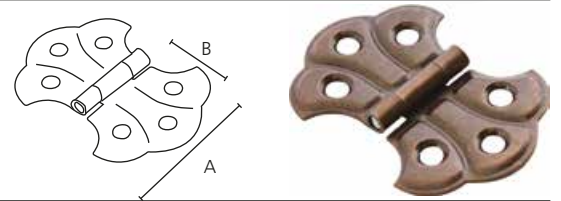

▶ Flush Overlay Hinge

- Self closing
- Opening angle 180° plus
- Includes screws and buffers
- Antique brass finish

Code	A	B	C	D	Pack Size
222.91970.338	70	13	41	30	100

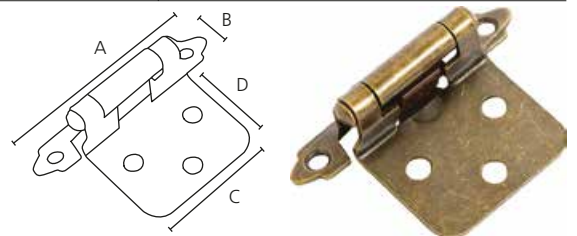

▶ Flush Overlay Hinge

- Non-self closing
- Opening angle 180° plus
- Includes screws
- Antique brass finish

Code	A	B	C	D	Pack Size
222.10170.338#	70	11	38	32	50

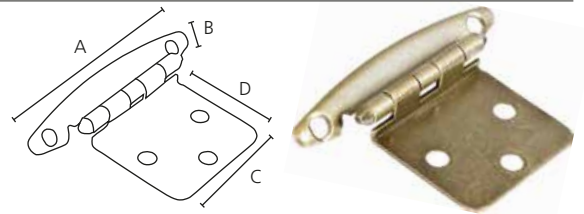

▶ Flush Overlay Hinge

- Decorative design
- Non-self closing
- Opening angle 180° plus
- Nickel plate and electroplated brass finish

Code	A	B	C	D	Pack Size
222.02180.332#	80	13.5	38	21	500

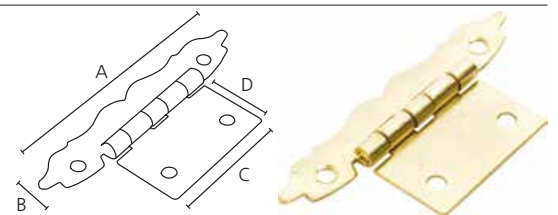

 **Finish: Nickel Plate (.332)**

BUILDERS' HARDWARE

CABINET HINGES

► Hirline Hinge

- Offset knuckle
- Countersunk screw holes
- Florentine bronze, electroplated brass and zinc plated finishes

Code	A	B	C	D
220.59051.337	51	17	30	13
220.59051.344	51	17	30	13
220.59051.352	51	17	30	13
220.59064.337	64	19	34	13
220.59064.344	64	19	34	13

 **Finish: Florentine Bronze (.337)**

 **Finish: Electroplated Brass (.344)**

 **Finish: Zinc Plate (.352)**

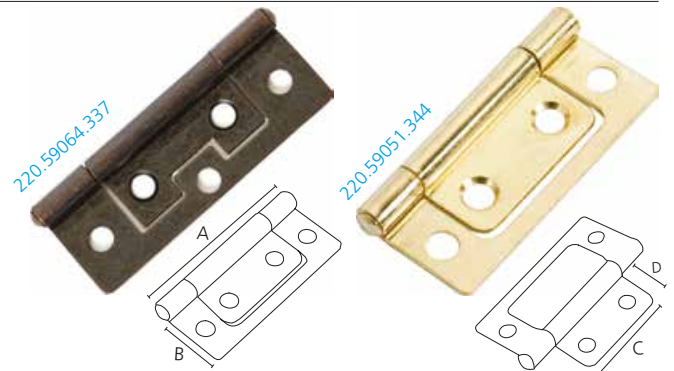

► Solid Brass Butt Hinge

- Solid brass construction
- Solid brass centre pin
- Brass and polished brass finishes

Code	A	B	Pack Size
221.27025.421	25	11	50
221.27050.420	50	15	25
221.27064.420	64	18	20

 **Finish: Brass (.420)**

 **Finish: Polished Brass (.421)**

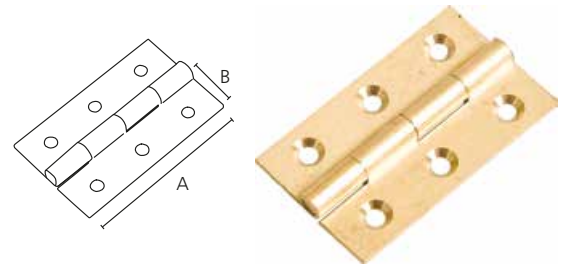

SHELF SUPPORTS

► Plastic Shelf Support

- Suits Ø 5mm drilled hole
- Steel support pin
- 1mm shelf clearance required
- White and clear finish
- Sold in boxes of 1000 pieces

Code	Finish	A	B	Pack Size
083201	.001	5	10	1000
083211	.125	5	10	1000

 **Finish: Clear (.125)**

 **Finish: White (.001)**

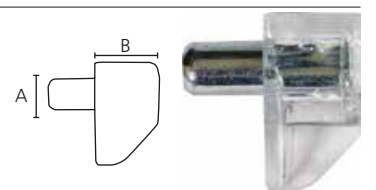

► Steel Shelf Support for Ø 6.35mm Boring

- Suits Ø 6.35mm drilled hole
- 1.5mm shelf clearance required
- Nickel plate finish

Code	A	B	C	Pack Size
047050	6.35	18	1.4	500

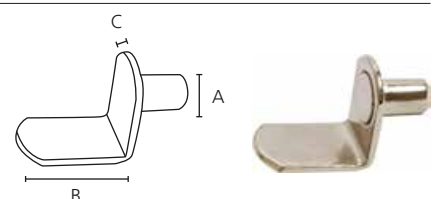

BUILDERS' HARDWARE

SHELF SUPPORTS

▶ Flanged Steel Shelf Support

- Suits Ø 5mm drilled hole
- Zinc plate finish

Code	A	B	Pack Size
210.39304.352	5	7	1000

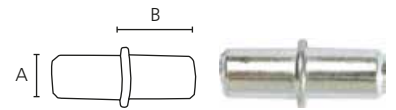

▶ Flanged Steel Shelf Support with Non Slip End

- Suits Ø 5mm drilled hole
- Non slip end cap
- Suitable for glass shelves
- Zinc plated / clear finish

Code	A	B	C	Pack Size
210.40306.352	5	9	7.5	1000



▶ Steel Shelf Support

- Suits Ø 5mm drilled hole
- Nickel plate finish

Code	A	B	Pack Size
290032	5	12	2500

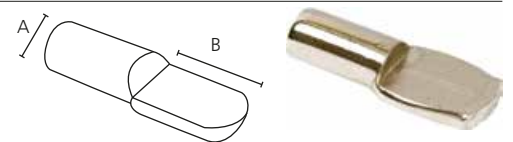

▶ Solid Brass Shelf Support

- Suits Ø 6.35mm hole or Ø 8mm hole
- 1.5mm shelf clearance required
- Brass finish

Code	Type	A	B	C	Pack Size
210.56301.420	Shelf support	6.35	8		200
210.57101.420	Bush	8	6.35	8	400

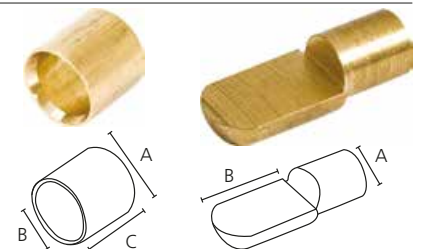

▶ Shelf Retaining Clip

- Suits Ø 5mm drilled hole
- Natural plastic finish

Code	A	B	C	Pack Size
210.15402.205	5	20	19	5000

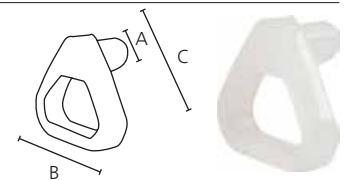

SHELF BRACKETS

▶ Adjustable Shelf Bracket

- Adjustable to suit shelf thickness 4mm - 25mm
- Suits glass or solid shelves
- Aluminium paint finish

Code	A	B	C	D	E	F	G	Pack Size
272.23025.368#	94	51	32	67	17	24	5	100
272.24040.368#	124	67	38	85	21	31	7	100

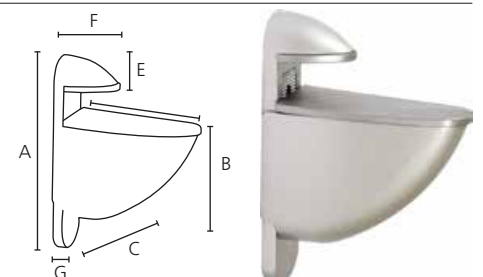

▶ Fold Down Shelf Bracket

- Trigger release
- Auto locking in open position
- Spring assisted opening
- White finish
- 50kg rating

Code	A	B	C	Pack Size
272.40200.001	136	200	31	12
272.40300.001	136	300	31	12

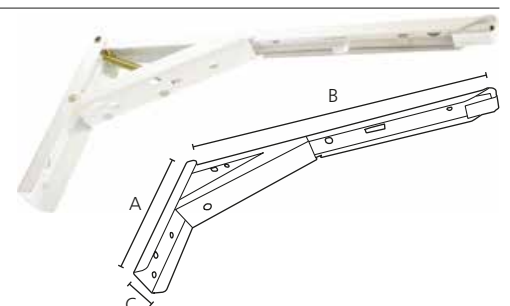

BUILDERS' HARDWARE

SHELF BRACKETS

► Fold Down Shelf Bracket

- Trigger release
- Auto locking in open position
- Supports approx 80kg (evenly distributed)
- Screws, spacers and wall plugs included
- Sold in pairs
- White finish

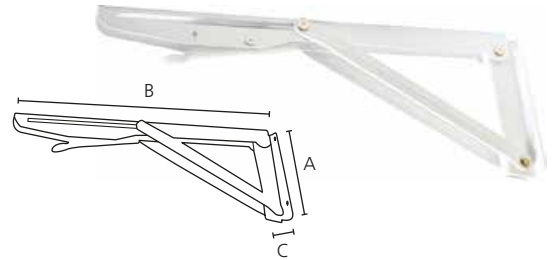

Code	A	B	C	Pack Size
054525	113	310	37	6

► Metal Shelf Support Systems

- Metal strip with pre punched holes at 15mm C/C
- 1800mm length
- Zinc plate or florentine bronze finish



Code	A	B	C	Finish	Pack Size
Shelf Strips					
080550	16	5	1800	Zinc plate	1
080560	16	5	1800	Florentine bronze	1
Shelf Supports					
080555	16	15	20	Zinc plate	100
080565	16	15	20	Florentine bronze	100

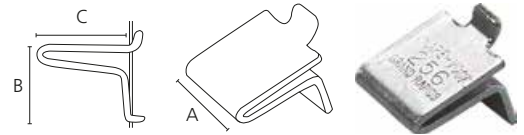
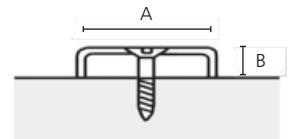

GLASS AND MIRROR CLIPS

► Plastic Mirror / Glass Clip

- High impact plastic
- Leaf shape
- Suits 3mm and 4mm glass thickness
- Used on edge
- Clear finish

Code	A	B	C	Pack Size
212.20303.126#	10.5	19	3	5000
212.20304.126#	10.5	19	4	5000

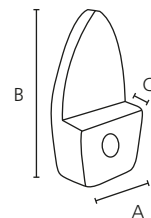

212.20303.126 212.20304.126

LEVELLERS

► Furniture Leveller

- Multi step plastic wedge for quick easy and economical levelling of furniture and kitchen cupboard installations
- Insert wedge to desired height step, then snap off remaining portion
- 8 Height options
- Made in Australia
- Black finish

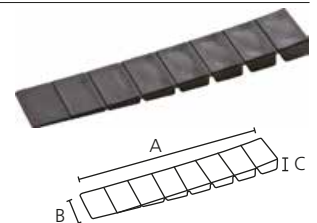

Code	A	B	C	Pack Size
217.10520.002	105	20	8	1000

PROTECTORS

► Corner Door Protector

- Plastic corner protector for doors and panels
- PVC (soft plastic) provides easy fitting
- 2 Sizes for 16mm and 18mm doors
- Black finish

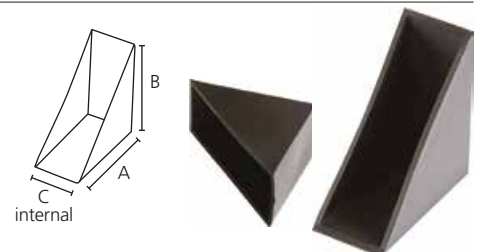

Code	A	B	C	Pack Size
231.30189.002	44	44	18	60

BUILDERS' HARDWARE

PROTECTORS

▶ Corner Door Protector

- Staple on corner glide protects cabinets / furniture
- White finish
- Sold in pairs (LH & RH)

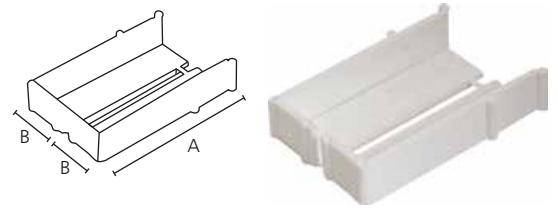

Code	A	B	Pack Size
231.10060.001	60	16	500

 **Finish: White/W (.001)**

▶ Furniture / Benchtop Protection

- Plastic corner protector for desks and benchtops
- Heavy duty design 1.4mm thick
- 2 Sizes for 33mm or 38mm panels
- Black finish



Code	A	B	C	Pack Size
231.45332.002	68	30	35	300
231.45382.002	38	38	38	1000

CASH MANAGEMENT

▶ Drawer Insert

- 6 Note and 6 coin compartments
- High-tech impact resistant
- Adjustable note sections with fixed coin sections
- Chrome plated and spring loaded note clips
- Black plastic
- 50mm depth

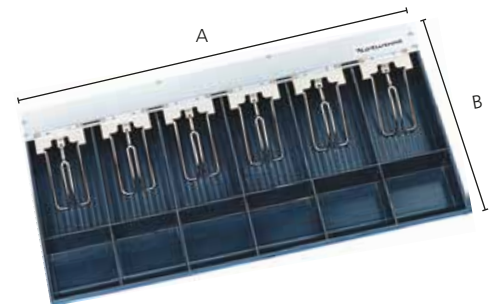

Code	A	B	Pack Size
662032	498	285	1

▶ Drawer Insert

- 5 Note and 5 coin compartments
- Includes lockable lid
- High-tech impact resistant
- Adjustable note sections with fixed coin sections
- Chrome plated and spring loaded note clips
- Black plastic
- 52mm depth

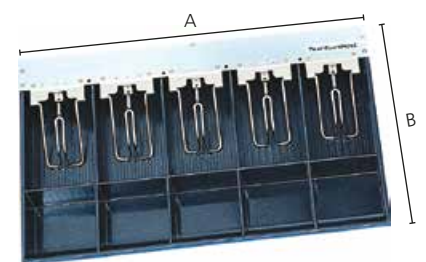

Code	A	B	Pack Size
662050	407	280	1

▶ Drawer Insert

- 5 Note and 8 coin compartments
- High-tech impact resistant
- Includes credit card payment slip compartment
- Coin wrapping aid
- Chrome plated and spring loaded note clips
- Black plastic
- 50mm depth

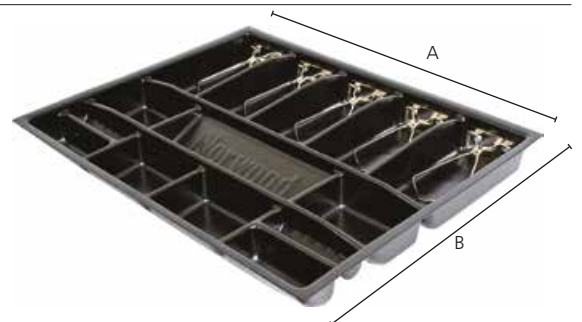

Code	A	B	Pack Size
662065	495	405	1

BUILDERS' HARDWARE

CASH MANAGEMENT

▶ Drawer Insert

- 4 Note and 8 coin compartments
- High-tech impact resistant
- Chrome plated and spring loaded note clips
- Designed to fit cash drawer 662095
- Black plastic
- 62mm depth
- Cover optional

Code	A	B	Pack Size
662107	370	370	1

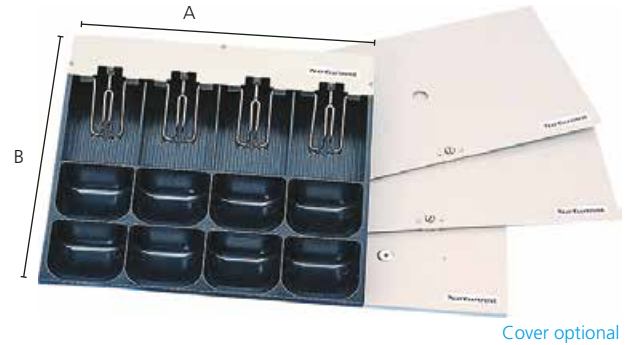

▶ Drawer Insert

- 4 Note and 6 coin compartments
- Includes \$1.00 Coil dispenser and coin wrapping aid
- High-tech impact resistant
- Chrome plated and spring loaded note clips
- Black plastic
- 50mm depth

Code	A	B	Pack Size
662035	370	280	1

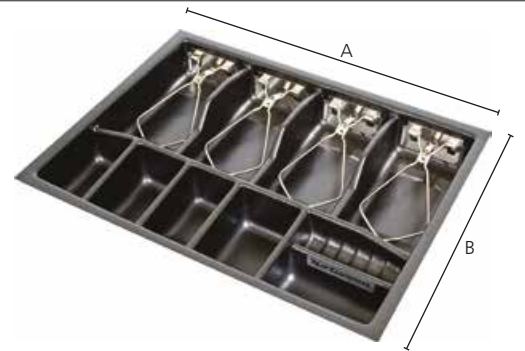

▶ Drawer Insert

- 3 Note and 6 coin compartments
- Includes \$1.00 Coil dispenser and coin wrapping aid
- High-tech impact resistant
- Chrome plated and spring loaded note clips
- 38mm depth

Code	A	B	Pack Size
662025	280	330	1

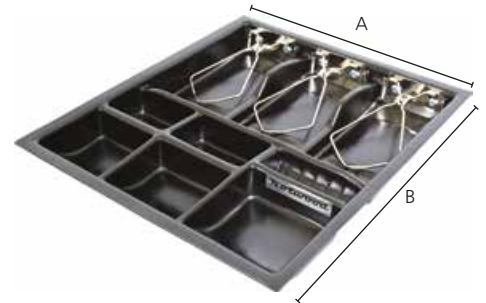

▶ Self-Contained Steel Cash Drawer

- 3 Note and 4 coin compartments
- Spring loaded catch and quick push front release
- Includes audible bell
- High-tech impact resistant
- Chrome plated and spring loaded note clips
- Manual operation
- Black finish

Code	A	B	C	Pack Size
662075	330	420	90	1

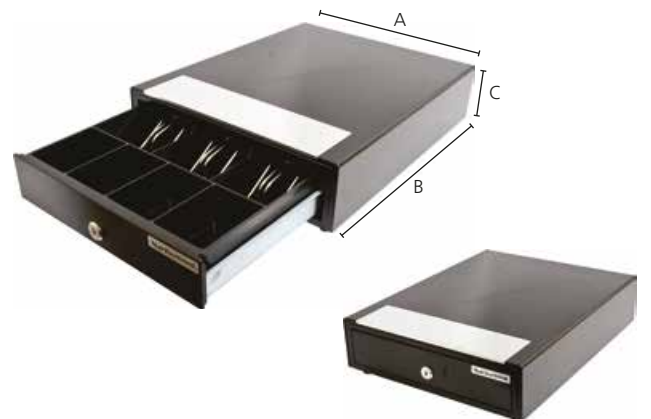

BUILDERS' HARDWARE

CASH MANAGEMENT

▶ Self-Contained Steel Cash Drawer

- 5 Note and 5 coin compartments
- Spring loaded catch and quick push front release
- Includes audible bell
- High-tech impact resistant
- Chrome plated and spring loaded note clips
- Manual operation
- Black finish

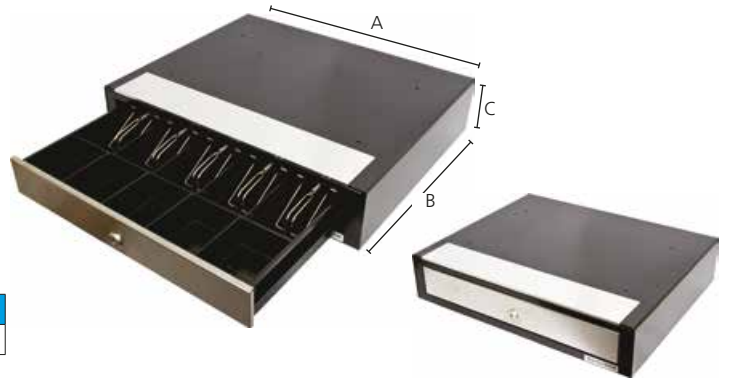

Code	A	B	C	Pack Size
662080	480	385	100	1

▶ Point of Sale Steel Cash Drawer

- Fitted with RJ11 connector for triggering by docket printer
- C/w cash drawer insert 662107
- 3 Key position drawer lock for electronic activation, operator activation and manual override
- Drawer front incorporates 2 media slots for checks and large denomination notes



Code	A	B	C	Pack Size
662095	440	460	105	1

TUBE CLOSURES

▶ Round

- Round plastic tube closures
- Fit internally
- To find correct size, measure outside of tube "A" and wall thickness
- Available in sizes 1/2" - 3"
- For other sizes or colours, please check availability



Code	A	Wall (mm)	Pack Size
P769X1/2BL	1/2"	1.6	1000
P769X5/8-001	5/8"	1.6	1000
P769X5/8-002	5/8"	1.6	1000
P769X3/4W	3/4"	1.6	1000
P769X3/4BL	3/4"	1.6	1000
P769X7/8BL	7/8"	1.6	1000
P769X1W	1"	1.6	1000
P769X1BL	1"	1.6	1000
P769X11/8BL	1-1/8"	1.6	1000
P769X30BL	30	1.6	1000
P769X11/4BL	1-1/4"	1.6	1000
P778X35BL	35	1.6	1000
P778X11/2BL	1-1/2"	1.6	1000
P778X40BL	40	1.6	1000
P778X13/4BL	1 3/4"	1.6	500
P778X50BL	50	1.6	500
P778X2BL	2"	1.6	400
P778X21/2BL	2 1/2"	1.6	250
P778X3BL[^]	3"	1.6	200

 Finish: White/W (.001)

 Finish: Black/BL (.002)

BUILDERS' HARDWARE

TUBE CLOSURES

▶ Round Nylon

- Round nylon tube closures
- Fit internally
- To find correct size, measure outside of tube "A" and wall thickness
- For other sizes or colours, please check availability

Code	A	Wall (mm)	Pack Size
N769X7/8BL	7/8"	1.6	1000
N769X1BL ^	1"	1.6	1000
N769X11/4BL ^	1-1/4"	1.6	1000

 **Finish: Black/BL (.002)**



▶ Exactapak

- Round domed plastic tube closures
- Fit internally
- To find correct size, measure outside of tube "A" and wall thickness
- For other sizes or colours, please check availability

Code	A	Wall (mm)	Pack Size
P769DX3/4BL ^	3/4"	1.6	1000
P769DX7/8BL	7/8"	1.6	1000
P769DX1BL	1"	1.6	1000

 **Finish: Black/BL (.002)**



▶ Square

- Square plastic tube closures
- Fit internally
- To find correct size, measure outside of tube "A,B" and wall thickness
- Available in sizes 1/2" - 60mm
- For other sizes or colours, please check availability

Code	A	B	Wall (mm)	Pack Size
P780X1/2BL	1/2"	1/2"	1.6	1000
P780X5/8BL	5/8"	5/8"	1.6	1000
P780X3/4BL	3/4"	3/4"	1.6	1000
P780X20BL	20	20	1.6	1000
P780X7/8BL	7/8"	7/8"	1.6	1000
P780X1W ^	1"	1"	1.6	1000
P780X1BL	1"	1"	1.6	1000
P780X30BL	30	30	1.6	1000
P780X11/4BL	1-1/4"	1-1/4"	1.6	1000
P780X35BL	35	35	1.6	1000
P780X11/2BL	1-1/2"	1-1/2"	1.6	500
P780X40BL	40	40	1.6	500
P780SX2BL	2"	2"	1.6	250
P780RX2BL	2"	2"	3.2	250

 **Finish: White/W (.001)**

 **Finish: Black/BL (.002)**

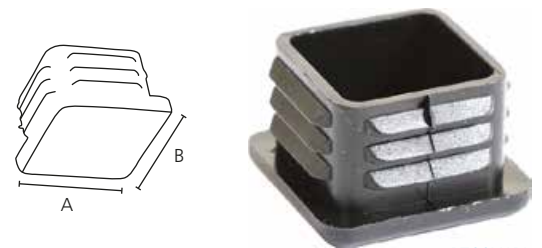

P780X1BL



P780SX2BL



P780RX2BL

BUILDERS' HARDWARE

TUBE CLOSURES

▶ Square Nylon

- Square nylon tube closures
- Fit internally
- To find correct size, measure outside of tube "A,B" and wall thickness
- For other sizes or colours, please check availability

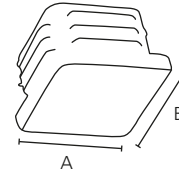

Code	A	B	Wall (mm)	Pack Size
N780X1BL	1"	1"	1.2 - 1.6	1000
N780X11/4BL	1-1/4"	1-1/4"	1.2 - 1.6	1000

Finish: Black/BL (.002)

▶ Square Angled

- Square angled nylon tube closures
- Fits internally
- To find correct size, measure outside of tube "A,B" and wall thickness
- Suits 3/4" tube with 1.2mm - 1.6mm wall
- Black finish

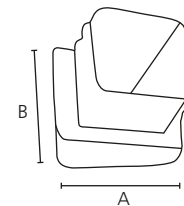

Code	A	B	Wall (mm)	Pack Size
N772X3/4BL	3/4"	3/4"	1.2 - 1.6	1000

Finish: Black/BL (.002)

▶ Oval

- Oval tube closures
- Fit internally
- To find correct size, measure outside of tube "A,B" and wall thickness
- Available in plastic or nylon

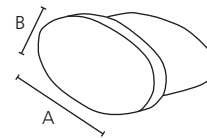

Code	Material	A	B	Wall (mm)	Pack Size
820.65331.002	nylon	1-1/4"	5/8"	1.6	1000
820.65332.002	plastic	1-1/4"	5/8"	1.6	1000
N2004BL	nylon	1-1/4"	11/16"	1.6	1000

Finish: Black/BL (.002)

▶ Rectangular

- Rectangular plastic tube closures
- Fit internally
- To find correct size, measure outside of tube "A,B" and wall thickness
- For other sizes or colours, please check availability

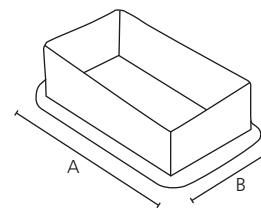

Code	A	B	Wall (mm)	Pack Size
P1446BL	1 3/8"	3/4"	1.6	1000
P1475BL	1-1/2"	1"	1.6	1000
P2019BL	50	20	1.6	1000
820.75512.002	50	25	2.5	500
P2000BL	2"	1"	1.6	500
P2003BL[^]	2"	1-1/4"	1.6	500
P2023X1.6BL	57	35	1.6	500
P2020BL	65	35	2	500
P2018BL[^]	2 1/2"	1-1/2"	-	400

Finish: Black/BL (.002)

BUILDERS' HARDWARE

TUBE CLOSURES

▶ Rectangular Nylon

- Rectangular nylon tube closures
- Fit internally
- To find correct size, measure outside of tube "A,B" and wall thickness
- For other sizes or colours, please check availability

Code	A	B	Wall (mm)	Pack Size
820.75511.002 [^]	50	25	2.5	500
N2000BL	2"	1"	1.6	500
820.75751.002 [^]	76	38	1.6	300

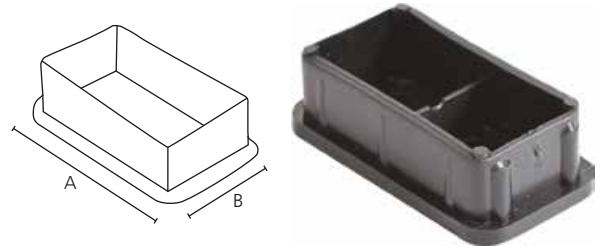

● **Finish: Black/BL (.002)**

▶ Rectangular Nylon

- Round plastic tube caps
- Fit externally
- Heavy duty design, domed base
- To find correct size, measure outside tube diameter (A)
- For other sizes or colours, please check availability

Code	A	B	Pack Size
P785X5/8BL	5/8"	29	1000
P785X3/4BL [^]	3/4"	32	1000
P785X7/8BL	7/8"	36	1000
P785X1W	1"	40	1000
P785X1BL	1"	40	1000

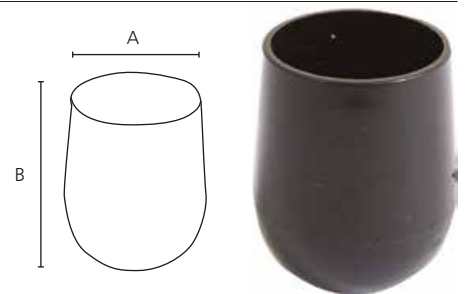

● **Finish: White/W (.001)**

● **Finish: Black/BL (.002)**

▶ Round External Nylon

- Round nylon tube caps
- Fit externally
- Heavy duty design, domed base
- To find correct size, measure outside tube diameter "A"

Code	A	B	Pack Size
N785X3/4BL	3/4"	32	1000
N785X7/8BL	7/8"	36	500

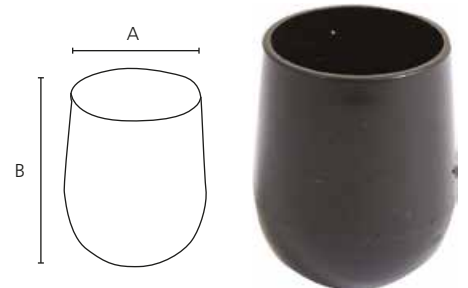

● **Finish: Black/BL (.002)**

▶ Round External

- Round plastic tube caps
- Fit externally
- Flat base
- To find correct size, measure outside tube diameter "A"
- For other sizes or colours, please check availability

Code	A	B	Pack Size
P803X10W	10	16	1000
P803X3/4BL	3/4"	25	1000
P803X1W [^]	1"	28	1000
P803X1BL	1"	28	1000
P803X11/4BL	1-1/4"	32	1000

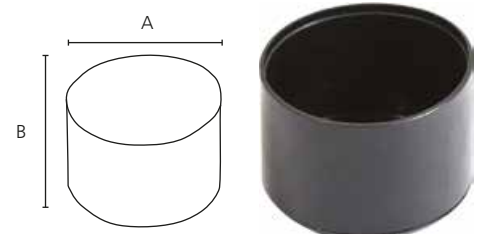

● **Finish: White/W (.001)**

● **Finish: Black/BL (.002)**

BUILDERS' HARDWARE

TUBE CLOSURES

► Square Angled

- Square plastic tube glide
- Fit externally
- Round base design allows for multiple angles
- Heavy duty design
- Suits 1" square tube

Code	A	B	Pack Size
821.73602.002	1"	1"	500

 **Finish: Black/BL (.002)**

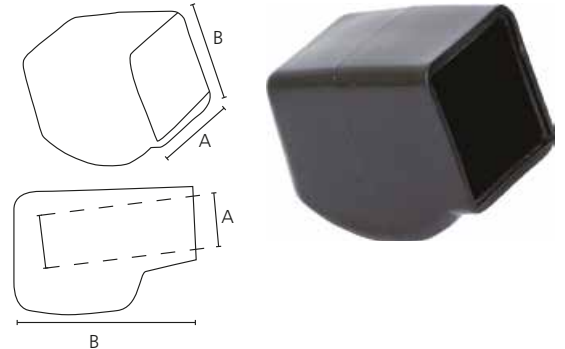

► Square Angled Nylon

- Square nylon angled tube glide
- Fit externally
- Heavy duty design
- Suits 1" square tube

Code	A	B	Pack Size
N186X1BL	1"	1"	400

 **Finish: Black/BL (.002)**

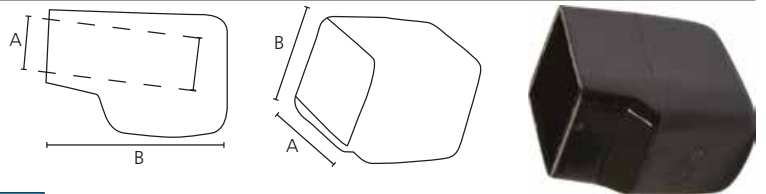

► Oval External

- Square nylon oval tube glide
- Fit externally
- To find correct size, measure outside of tube

Code	A	B	Pack Size
821.65321.002	1-1/4"	5/8"	500

 **Finish: Black/BL (.002)**

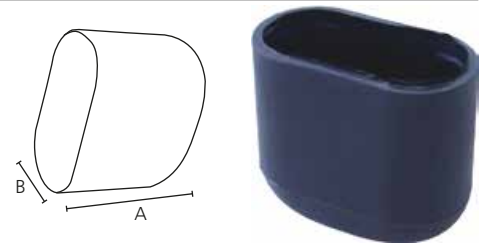

► Rubber

- Round rubber tube caps
- Fit externally
- Heavy duty design
- To find correct size, measure outside tube diameter "A"
- Available in sizes 9.5mm - 38mm

Code	A	B	Pack Size
825.10950.002^A	9.5	29	2300
825.10130.002	13	29	2000
825.10160.001	16	29	1600
825.10160.002	16	29	1600
825.10190.001	19	29	1200
825.10190.002	19	29	1200
825.10220.001	22	34	900
825.10220.002	22	34	900
825.10250.001	25	38	600
825.10250.002	25	38	600
825.10320.001	32	43	400
825.10320.002	32	43	400
825.10380.002	38	43	300

 **Finish: White/W (.001)**

 **Finish: Black/BL (.002)**



BUILDERS' HARDWARE

TUBE CLOSURES

► Metal Round

- Round metal spring closures
- Fit internally
- Slightly domed design
- To find correct size, measure outside of tube "A" and wall thickness
- For other sizes or colours, please check availability

Code	A	Wall (mm)	Pack Size
P274X5/8NP	5/8"	1.2 - 1.6	1000
P274X3/4NP	3/4"	1.2 - 1.6	1000
P274X3/4RAW	3/4"	1.2 - 1.6	1000
P274X7/8NP	7/8"	1.2 - 1.6	1000
P274X1NP	1"	1.2 - 1.6	1000
P274X1RAW	1"	1.2 - 1.6	1000
P274X11/4NP	1-1/4"	1.2 - 1.6	1000
P274X11/4RAW	1-1/4"	1.2 - 1.6	1000
P274X11/2NP	1-1/2"	1.2 - 1.6	1000
P274X11/2RAW	1-1/2"	1.2 - 1.6	1000
P274X2RAW	2"	1.2 - 1.6	1000

 **Finish: Raw Zinc (.RAW)**

 **Finish: Nickel Plate (.NP)**



► Metal Square

- Square metal tube closures
- Fit internally
- Flat design
- To find correct size, measure outside of tube "A,B" and wall thickness
- Available for 3/4" & 1" tube in nickel plate

Code	A	B	Wall (mm)	Pack Size
P275X3/4NP[^]	3/4"	3/4"	1.2 - 1.6	1000
P275X1NP[^]	1"	1"	1.2 - 1.6	1000

 **Finish: Nickel Plate (.NP)**

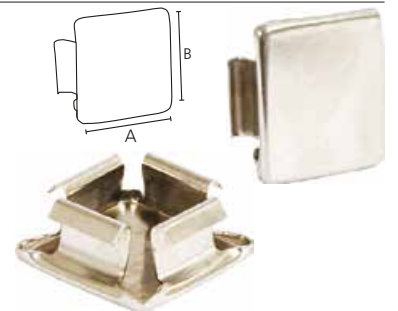

► Round Metal

- Round metal threaded adaptor
- Fits internally
- To find correct size, measure outside of tube "A" and wall thickness
- N.B. Not recommended for use with castors, see sockets
- Zinc plate finish

Code	A	B	Wall (mm)	Pack Size
P305-7/8X5/16ZP	7/8"	5/16" nut	1.2 - 1.6	1000
P305-1X5/16ZP	1"	5/16" nut	1.2 - 1.6	1000
P305-1X3/8	1"	3/8" nut	1.2 - 1.6	1000
P305-2X3/8ZP	2"	3/8" nut	1.2 - 1.6	500



► Square Metal

- Square metal threaded adaptor
- Fits internally
- To find correct size, measure outside of tube "A,B" and wall thickness
- N.B. Not recommended for use with castors, see sockets
- Zinc plate finish

Code	A	B	C	Wall (mm)	Pack Size
P307-3/4X5/16ZP	3/4"	3/4"	5/16" nut	1.2-1.6	1000
P307-7/8X5/16ZP	7/8"	7/8"	5/16" nut	1.2-1.6	1000
P307-1X5/16ZP	1"	1"	5/16" nut	1.2-1.6	1000
P307-1X3/8ZP	1"	1"	3/8" nut	1.2-1.6	1000
P307-11/4X5/16ZP	1-1/4"	1-1/4"	5/16" nut	1.2-1.6	1000
P307-11/4X3/8ZP	1-1/4"	1-1/4"	3/8" nut	1.2-1.6	1000
P307-11/2X3/8ZP	1-1/2"	1-1/2"	3/8" nut	1.2-1.6	500
P307-2X3/8ZP	2"	2"	3/8" nut	1.2-1.6	500



BUILDERS' HARDWARE

SOCKETS FOR STEM CASTORS & GLIDES

▶ Socket – Grip Neck

- Socket to enable simple attachment to board
- For use with stem type castors
- Socket can be knocked into 9.5mm hole in timber and stem pushes into socket
- Suitable for MDF, soft woods
- Zinc plate finish

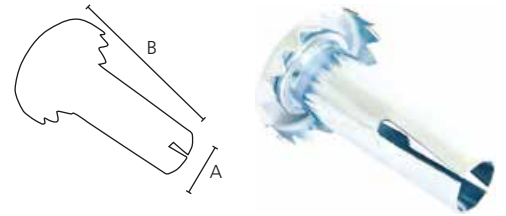

Code	A	Wall (mm)	Pack Size
816.28088.352	31	9.5	3000

THREADED ADAPTORS

▶ Round Nylon

- Round nylon threaded adaptors
- Comes with steel UNC threaded insert
- Fits internally
- To find correct size, measure outside of tube "A" and wall thickness
- N.B. Not recommended for use with castors, see sockets
- Black finish

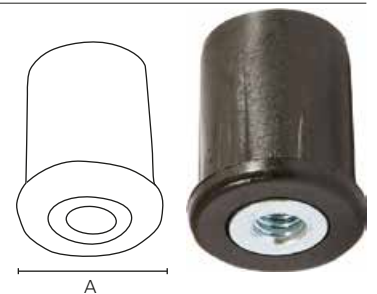

Code	A	B	Wall (mm)	Pack Size
N782-1X5/16BL [^]	1"	5/16" nut	1.6	1000
N782-11/4X3/8BL	1-1/4"	3/8" nut	1.6	400
N782-2X3/8BL [^]	2"	3/8" nut	1.6	200

▶ Square Nylon

- Square nylon threaded adaptor
- Comes with steel UNC threaded insert
- Fits internally
- To find correct size, measure outside of tube "A,B" and wall thickness
- N.B. Not recommended for use with castors, see sockets
- Black finish

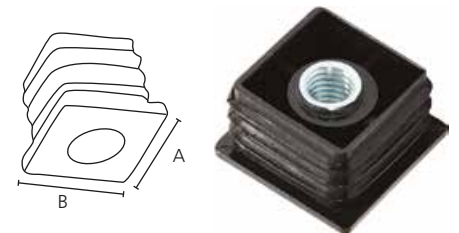

N791-11/4X3/8BL

Code	A	B	C	Wall (mm)	Pack Size
N791-1X3/8BL	1"	1"	3/8" nut	1.6	400
N791-30X3/8BL [*]	30	30	3/8" nut	1.6	800
N791-11/4X3/8BL	1-1/4"	1-1/4"	3/8" nut	1.6	500
N791-11/2X3/8BL	1-1/2"	1-1/2"	3/8" nut	1.6	250

^{*} tapped thread only

▶ Square Side Fix

- Square nylon closure, threaded adaptor
- Thread fix on side
- Fits internally
- To find correct size, measure outside of tube "A,B" and wall thickness
- Black finish



Code	A	B	C	Wall (mm)	Pack Size
815.95015.002	1"	1"	5/16" nut	1.6	1000

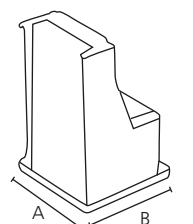

BUILDERS' HARDWARE

TUBE CONNECTORS

▶ Connectors

- Suits round or square tube
- Connects tubing to other tubing or virtually anything
- Eliminates need for welding
- Variety of sizes and thread types

Code	A	B	Wall (mm)	Pack Size
P304-11/4X5/16	1-1/4"	5/16" nut	1.2 - 1.6	2000
P304-1X1/4	1"	1/4" nut	1.2 - 1.6	2000
P304-3/4X1/4	3/4"	1/4" nut	1.2 - 1.6	2500
P304-1X5/16[^]	1"	5/16" nut	1.2 - 1.6	2000

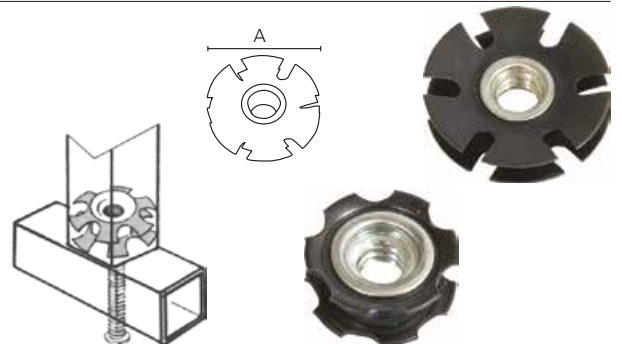

TUBE GLIDES

▶ Saddle

- Nylon saddle glide grips around tube
- Suits 1/2" to 5/8" diameter tube
- Heavy duty nylon
- Black finish

Code	A	Pack Size
N2015-1/2X5/8BL	1/2" - 5/8"	1000



▶ Stem Bumper

- Covered nylon stem bumper
- 6.35mm (1/4") stem
- To find correct size, measure outside tube diameter
- Black finish

Code	Tube	B	Pack Size
N764X11/4BL	1-1/4"	6.4	1000
N764X1BL	1"	6.4	1000
N764X7/8BL	7/8"	6.4	1000



REDUCING BUSHES

▶ 1-1/2"

- Nylon reducing bushes
- Reduces from 1-1/2" to 1" (25.4mm)
- Flanged and non flanged
- Black finish

Code	A	B	Wall (mm)	Pack Size
H1010-2BL[^]*	1-1/2"	1"	1.6	500
H1010-3BL[^]	1-1/2"	1"	1.6	500

* flanged



HANDWHEELS

▶ Tri-Wheel – Large

- Adjustable handwheel
- 65mm span
- Various UNC bolt sizes available
- Black finish

Code	A	B	C	Pack Size
313.44111.002	65	5/16"	11	500
313.44150.002	65	5/16"	22	500
313.44131.002	65	3/8"	20	500
313.44130.002	65	3/8"	22	500
313.43003.002*	65	3/8"		500

* nut only - 3/8" UNC thread

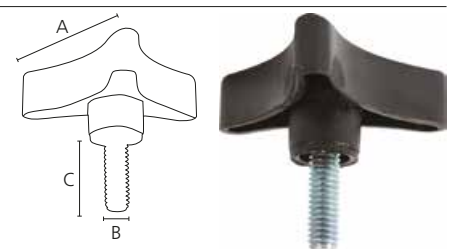

BUILDERS' HARDWARE

HANDWHEELS

▶ Tri-Wheel – Small

- Adjustable handwheel
- 38mm span
- Various UNC bolt sizes available
- Black finish

Code	A	B	C	Pack Size
313.46112.002	38	5/16"	13	1000
313.46140.002	38	1/4"	16	1000
313.46122.002	38	1/4"	22	1000
313.48004.002*	38	1/4"		1000

* nut only - 1/4" UNC thread

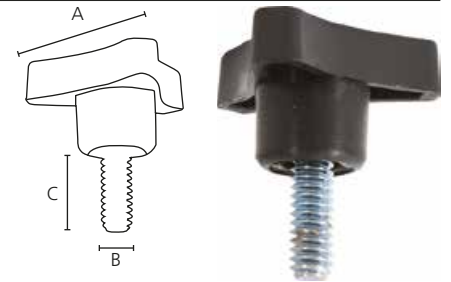

▶ Triangular

- Adjustable handwheel
- 27mm span
- 1/4" UNC x 16mm bolt
- Black finish

Code	A	B	C	Pack Size
313.80140.002	27	1/4"	16	1000

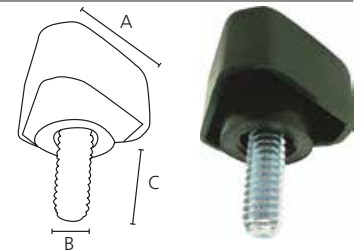

▶ 5-Point

- Adjustable handwheel
- 57mm span
- 3/8" or 5/16" UNC bolts
- Black finish

Code	A	B	C	Pack Size
313.84150.002	57	5/16"	22	500
313.84130.002	57	3/8"	22	500
313.83005.002*	57	5/16"		500

* nut only - 5/16" UNC thread

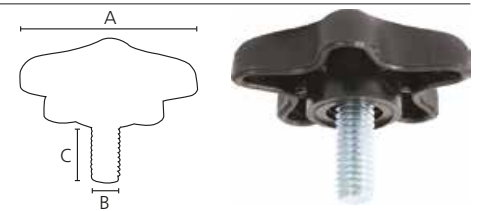

▶ Triangular

- Adjustable handwheel
- 27mm span
- 1/4" UNC x 16mm bolt
- Black finish

Code	A	B	C	Pack Size
313.81005.002*	75	5/16"		1000

* nut only - 5/16" UNC thread



▶ Round Notched

- Adjustable handwheel
- 22mm diameter
- 1/4" UNC x 16mm bolt
- Black finish

Code	A	B	C	Pack Size
313.77140.002	22	1/4"	16	1400

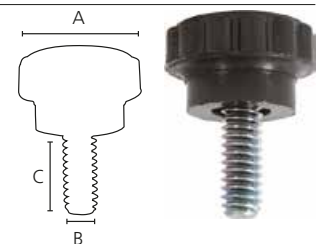

▶ Round Ball

- Adjustable handwheel
- 25mm diameter
- Nut only, available in 3/8" or 5/16" UNC
- Black finish

Code	A	B	C	Pack Size
313.85005.002	25	5/16"		1000

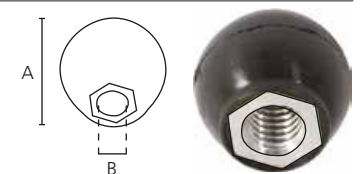

BUILDERS' HARDWARE

SPACERS

► Plastic & Nylon

- Available in various diameters and thicknesses
- Nylon (Z series) or plastic
- Black and white finishes

Code	A	B	C	Pack Size
818.04102.002	28	10	5	1000
818.04112.002	28	10	9	1000
818.04122.002 [^]	28	10	12	1000
818.04132.002	28	10	14	1000
Z181X1/4BL	19	6.4	10	1000
Z181X3/8BL	19	9.5	10	1000
Z229BL [^]	11	4.9	10	1000
P590X1/4W [^]	16	6.4	16	1000



STEM BUMPERS

► Stem – Black

- Nylon stem bumpers
- 10mm, 13mm or 19mm base
- 6.35mm (1/4") x 12mm stem
- Black finish

Code	A	B	C	D	Pack Size
N795X10BL [^]	10	6.35	3	12	5000
N795X13BL	13	6.35	3	12	5000
N795X3/4BL [^]	19	6.35	3	12	1000

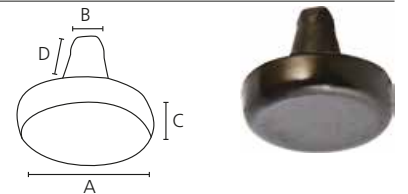

► Stem – Clear

- Plastic stem bumper
- 10mm diameter
- 6.35mm (1/4") x 12mm stem
- Clear finish

Code	A	B	C	D	Pack Size
P795X10-3C [^]	10	6.35	3	12	5000

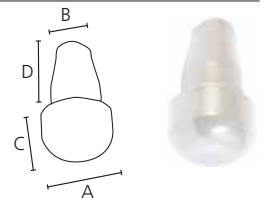

NYLON BUSHES

► Bushes

- Nylon bushes flanged or non flanged
- Various sizes available
- Black finish
- D = bore / hole size

Code	A	B	C	D	Pack Size
Z104BL	22	25.4	/	6.4	1000

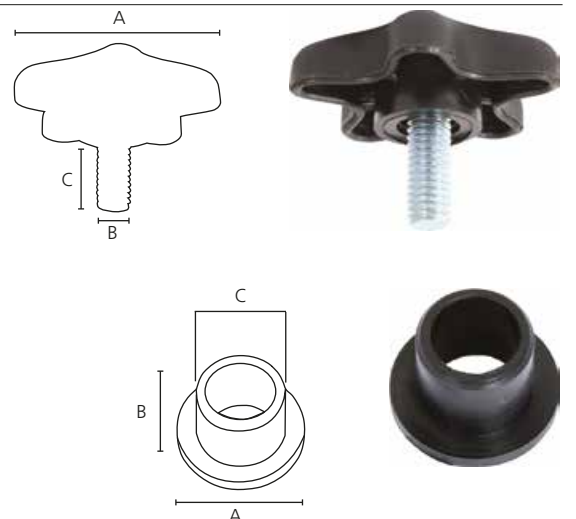

BUILDERS' HARDWARE

OFFICE FURNITURE EQUIPMENT

CABLE OUTLETS

▶ Cable Entry Caps – Aluminium

- High quality metal grommets for cable entry points in office and furniture workstations
- 2 Piece design
- 2 Sizes for 60mm or 76mm boring
- Satin aluminium finish

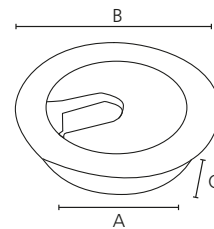

Code	A	B	C	Pack Size
255.70456.301	80	80	13	1

 **Finish: Satin Aluminium (.301)**

▶ Cable Entry Caps – Plastic

- Attractive and economical push-in caps dress cable entry points in office and furniture workstations
- Swivelling cover plates provide cable entry openings
- 2 Sizes for 60mm or 80mm boring
- Beige, black, oyster grey, silver grey, and white finishes

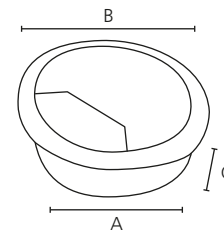

Code	Finish	A	B	C	Pack Size
047060	.016	60	71	21	250
047062	.002	60	71	21	250
047068	.015	60	71	21	250
047075	.014	60	71	21	250
047080	.001	60	71	21	250
047090	.016	80	91	21	300
047092	.002	80	91	21	300
047100	.001	80	91	21	300
047098	.015	80	91	21	300

 **Finish: White (.001)**

 **Finish: Black (.002)**

 **Finish: Silver Grey (.014)**

 **Finish: Oyster Grey (.015)**

 **Finish: Beige (.016)**

DIVIDER

▶ Shelf Divider

- Divider for files, cd's, catalogues etc
- Nickel plate finish

Code	A	B	C	Shape
054336#	270	6	150	D-Shape
055437#	270	6	195	Angled
054438	193	5	195	D-Shape

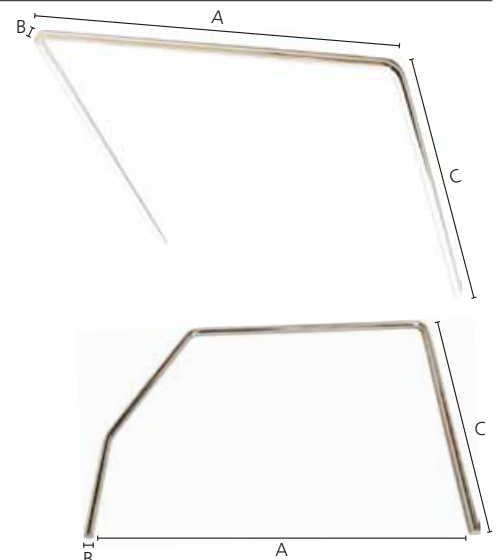

BUILDERS' HARDWARE

INDEX

Part Number.....	Page
210.15402.205.....	17
210.39304.352.....	17
210.40306.352.....	17
210.56301.420.....	17
210.57101.420.....	17
215.01100.352.....	12
215.11139.001.....	12
215.11140.001.....	13
215.42100.352.....	12
215.71338.420.....	12
215.71343.420.....	12
215.71349.420.....	12
215.71360.420.....	12
217.10520.002.....	18
220.59051.337.....	16
220.59051.344.....	16
220.59051.352.....	16
220.59064.337.....	16
220.59064.344.....	16
221.12036.337.....	15
221.27025.421.....	16
221.27050.420.....	16
221.27064.420.....	16
221.35025.344.....	15
222.02180.332#.....	15
222.10170.338#.....	15
222.91970.338.....	15
231.10060.001.....	19
231.30189.002.....	18
231.45332.002.....	19
231.45382.002.....	19
255.70456.301.....	31
272.23025.368#.....	17
272.24040.368#.....	17
272.40200.001.....	17
272.40300.001.....	17
274.03102.387.....	11
290.91930.340.....	03
290.92530.340.....	03
291.30153.340.....	03
313.43003.002.....	28
313.44111.002.....	28
313.44130.002.....	28
313.44131.002.....	28
313.44150.002.....	28
313.46112.002.....	29
313.46122.002.....	29
313.46140.002.....	29
313.48004.002.....	29
313.77140.002.....	29
313.80140.002.....	29
313.81005.002.....	29
313.83005.002.....	29
313.84130.002.....	29
313.84150.002.....	29
313.85005.002.....	29
815.95015.002.....	27
816.28088.352.....	27
818.04102.002.....	30
818.04112.002.....	30
818.04122.002^.....	30
818.04132.002.....	30
820.65331.002.....	23
820.65332.002.....	23
820.75511.002^.....	24
820.75512.002.....	23
820.75751.002^.....	24

BUILDERS' HARDWARE

INDEX PART NUMBERS

Part Number	Page
821.65321.002	25
821.73602.002	25
825.10130.002	25
825.10160.001	25
825.10160.002	25
825.10190.001	25
825.10190.002	25
825.10220.001	25
825.10220.002	25
825.10250.001	25
825.10250.002	25
825.10320.001	25
825.10320.002	25
825.10380.002	25
825.10950.002^	25
015037#	12
047050	16
047060	31
047062	31
047068	31
047075	31
047080	31
047090	31
047092	31
047098	31
047100	31
054210	13
054212	13
054436#	31
054437#	31
054438	31
054525	18
054535	13
075346	15
075350	15
075360	15
075362	15
075364	15
075366	15
080550	18
080555	18
080560	18
080565	18
083201	16
083211	16
185012	06
270208	13
270376	14
270378	14
270379	14
270383	14
270386	14
270387	14
270388	14
290032	17
426270	13
426272	13
426276	13
426330	13
426332	13
426334	13
426336	13
503018	06
503020	06
582021	11
630119	04
630120-1	04
630121-1	04
630125	04
630126-1	04
630127	04

BUILDERS' HARDWARE

INDEX PART NUMBERS

Part Number.....	Page
630129.....	05
630130.....	05
630131.....	05
630132.....	05
640125.....	03
640130.....	03
640135.....	03
662025.....	20
662032.....	19
662035.....	20
662050.....	19
662065.....	19
662075.....	20
662080.....	21
662095.....	21
662107.....	20
776002.....	09
776005.....	09
776037.....	08
776038.....	08
776043.....	11
776052.....	09
776053.....	09
776055.....	09
776059.....	09
776061.....	09
776064.....	09
776069.....	10
776103.....	11
776108.....	10
776110.....	10
776111.....	10
776113.....	10
776136.....	11
776138.....	10
776165.....	08
776245.....	07
776250.....	07
776305.....	08
776310.....	08
776320.....	07
776321.....	07
H1010-2BL^*.....	28
H1010-3BL^.....	28
N186X1BL.....	25
N764X1BL.....	28
N764X7/8BL.....	28
N764X1 1/4BL.....	28
N769X1BL^.....	22
N769X7/8BL.....	22
N769X1 1/4BL^.....	22
N772X3/4BL.....	23
N780X1BL.....	23
N780X1 1/4BL.....	23
N782-1X5/16BL^.....	27
N782-2X3/8BL^.....	27
N782-11/4X3/8BL.....	27
N785X3/4BL.....	24
N785X7/8BL.....	24
N791-1X3/8BL.....	27
N791-11/2X3/8BL.....	27
N791-11/4X3/8BL.....	27
N791-30X3/8BL.....	27
N795X3/4BL^.....	30
N795X10BL^.....	30
N795X13BL.....	30
N2000BL.....	24
N2004BL.....	23
N2015-1/2X5/8BL.....	28
P274X1NP.....	26
P274X1RAW.....	26

BUILDERS' HARDWARE

INDEX PART NUMBERS

Part Number	Page
P274X2RAW	26
P274X3/4NP	26
P274X3/4RAW	26
P274X5/8NP	26
P274X7/8NP	26
P274X11/2NP	26
P274X11/2RAW	26
P274X11/4NP	26
P274X11/4RAW	26
P275X1NP^	26
P275X3/4NP^	26
P304-1X1/4	28
P304-1X5/16^	28
P304-3/4X1/4	28
P304-11/4X5/16	28
P305-1X3/8	26
P305-1X5/16ZP	26
P305-2X3/8ZP	26
P305-7/8X5/16ZP	26
P307-1X3/8ZP	26
P307-1X5/16ZP	26
P307-2X3/8ZP	26
P307-3/4X5/16ZP	26
P307-7/8X5/16ZP	26
P307-11/2X3/8ZP	26
P307-11/4X3/8ZP	26
P307-11/4X5/16ZP	26
P590X1/4W^	30
P769DX1BL	22
P769DX3/4BL^	22
P769DX7/8BL	22
P780RX2BL	22
P780SX2BL	22
P780X1/2BL	22
P780X1BL	22
P780X1W^	22
P780X3/4BL	22
P780X5/8BL	22
P780X7/8BL	22
P780X11/2BL	22
P780X11/4BL	22
P780X20BL	22
P780X30BL	22
P780X35BL	22
P780X40BL	22
P785X1BL	24
P785X1W	24
P785X3/4BL^	24
P785X5/8BL	24
P785X7/8BL	24
P795X10-3C^	30
P803X1BL	24
P803X1W^	24
P803X3/4BL	24
P803X10W	24
P803X11/4BL	24
P1446BL	23
P1475BL	23
P2000BL	23
P2003BL^	23
P2018BL^	23
P2019BL	23
P2020BL	23
P2023X1.6BL	23
WACH_18_18	10
WACH_18_36	10
WAINS_18	10
Z104BL	30
Z181X1/4BL	30
Z181X3/8BL	30
Z229BL^	30



CABINET HARDWARE SYSTEMS

BUILDERS' HARDWARE

Version 1.0

Australia

1800 008 591 ■ www.artia.com.au

VICTORIA:

235 Settlement Road,
Thomastown VIC 3074

NEW SOUTH WALES:

Unit 1/429 Victoria Street,
Wetherill Park NSW 2164

QUEENSLAND:

Building 2/660 MacArthur
Avenue, Pinkenba QLD 4008

SOUTH AUSTRALIA:

13 Rosberg Road,
Wingfield SA 5013

WESTERN AUSTRALIA:

Unit 1B/15 Hector Street,
Osborne Park WA 6017

New Zealand

0800 267 625 ■ www.artia.co.nz

AUCKLAND:

11 Bruce Roderick Drive,
East Tamaki, Auckland 2013

CHRISTCHURCH:

117 Wrights Road,
Addington, Christchurch 8024